

Installation Guidelines

The subgrade has to be compacted to an $EV_2 > 45 \text{ MN/m}^2$, if the concrete base has an overlap of $> 50 \text{ cm}$ from channels end. Otherwise, it has to be compacted to an EV_2 of $> 180 \text{ MN/m}^2$, or it must be ensured that in case of heavy trucks circulation an overlap of $> 50\text{cm}$ from channels end is guaranteed

The dimensioning of the lateral concrete surrounding (x) must be adapted to local site conditions and equals at least 15 cm. In cases where the connection between subgrade and lateral concrete surrounding of the channel is avoided by for example by expansion joints, then dowel bars made of $\varnothing 8 \text{ mm}$ reinforced steel have to be installed every 30 cm.

Ⓢ The concrete grades indicated are minimum values. Requirements related to the location of installation, such as resistance to freeze-thaw with de-icing salts, must be taken into account by choosing the appropriate concrete grade in accordance with DIN 1045-2, DIN EN 206-1 and DIN-technical report 100 respectively.

With complete concrete surrounded channels system, BIRCO recommends a fully sealing of the channel joints, so as to prevent damage through freeze – thaw conditions (see jointing information!)

It must be ensured that installation is performed expertly, taking into account concrete technology aspects.

All adjoining pavement surfaces must run permanently at a level of some 3 to 5 mm higher than the upper edge of the channel. In order to achieve this, we recommend laying the first two to three rows of block paving or paving slabs in the mortar bed. Because there is no concrete encasing, the surfacing can run right up to the channel. In the case of block paving or paving slabs being used as the adjoining surfacing, a durable sealing joint of some 10 mm must be established between the channel and the surfacing. The joints between the first two to three rows of the block paving or paving slabs must be sealed durably in a tight and impermeable manner. It must be ensured that horizontal forces, which may result from the expansion or shifting of the pavement, have no impact on the two to three rows of pavement set in the mortar bed.

Expansion joints in the construction parts adjoining the channel must be planned on the basis of engineering considerations. BIRCO recommends arranging expansion joints parallel to the channel, at a distance of some 0.2 to 0.5 metres from the channel line. Expansion joints running transverse to the channel line must be arranged so that they run through a channel joint. We recommend arranging them every 8 to 12 metres (in accordance with DIN 18318, valid edition). The expansion joints (e.g. PE foam sheets) must cover the total cross-sectional area of the channel, as well as the full area of the concrete base and the lateral concrete encasing.

Jointing Information

Sealing of the channel joint / safety seam with SF-Connect after the laying of the drainage channels.

Areas of application: Adhesion of concrete, clinker, steel, stainless steel, aluminium, polyester (GFK), PVC, acrylic, polystyrene, glass, wood.

Properties:

Coated bases must be inspected in advance for adhesion and compatibility. The hardening period depends on the temperature and moisture. Higher temperatures reduce the drying period time. SF-Connect does not contain solvents, isocyanate and silicones and does not require special warning labelling. Prior to beginning the work, it is necessary to make oneself familiar with the handling and safety instructions by reading the material safety data sheet.

Working Instructions:

1. Use the industrial grouting pistol (item code 608500) to apply the sealant to the channel joint / safety seam.
2. Prior to applying the sealant to the safety joint, clean the channel end / safety seam and remove separating agents, dust, soiling, oil and other residues that could inhibit adhesion.
3. Wear protective gloves and eyewear when conducting the work.
4. Insert tubular bag (600 ml) into the industrial grouting gun.
5. Inject SF-Connect into joint.
6. Then smooth out the channel joint / safety seam surface with a jointer or putty knife that has been dipped in a soap solution.
7. Allow material residue to dry. Dried residue can be disposed of as residual waste.

Bolt Connection Information:

For screw fastening of the gratings, torque moments are to be set at $M12 = 60 \text{ Nm}$, $M16 = 100 \text{ Nm}$. The bolts must be re-tightened at regular intervals.

Additional regulations and guidelines

Local particularities have to be examined and taken into account by the planner. Installation must comply with the latest international/local regulations and guidelines .
+ The correct load class in accordance with DIN EN 1433 "Drainage channels for vehicular and pedestrian areas" has to be respected.

BIRCO SIR NW 200, Typ M
class A 15 – E 600 [*]

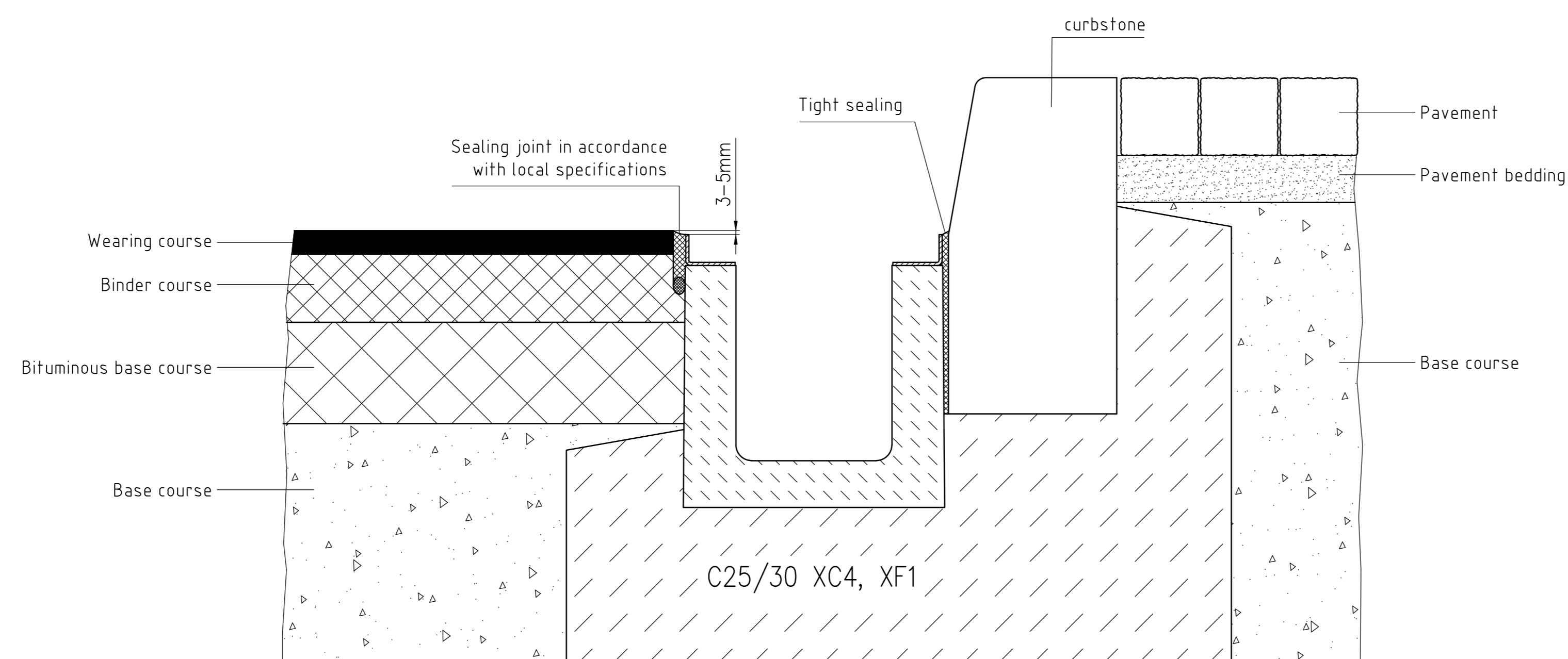

Constructed in accordance with local specifications using non-setting frost-free sub-bases (E.g. RST0)

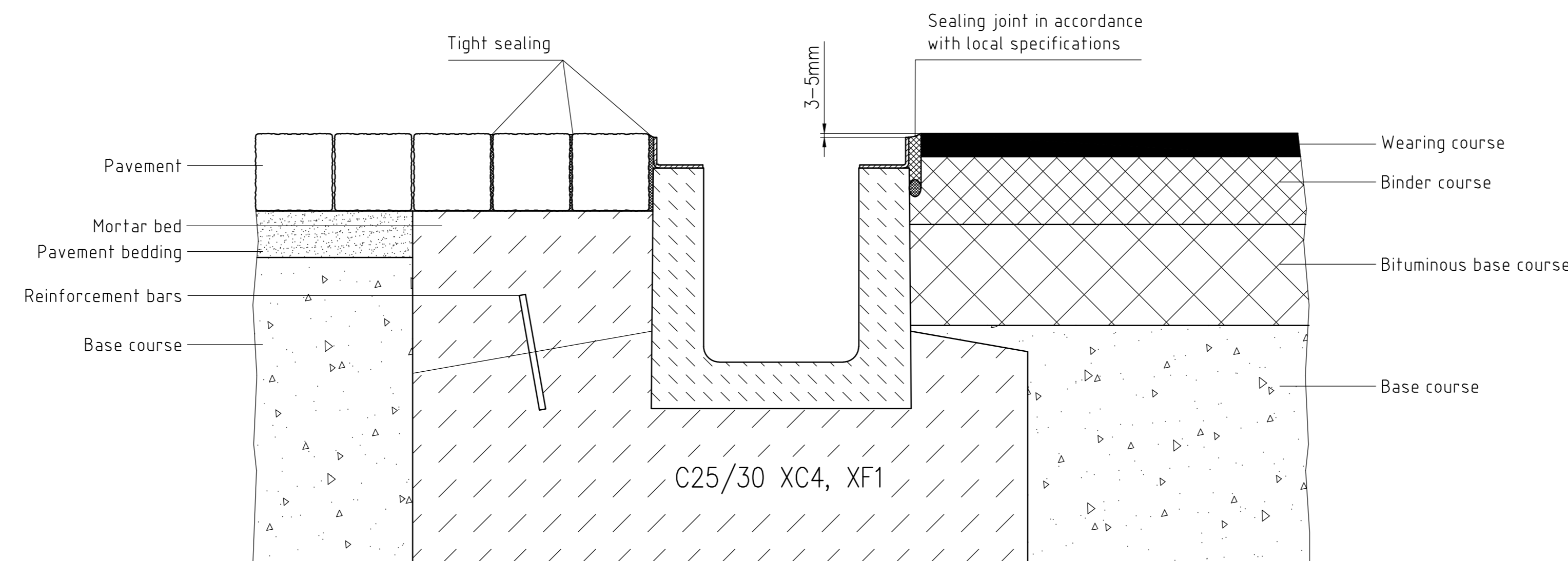

Constructed in accordance with local specifications using non-setting frost-free sub-bases (E.g. RST0)

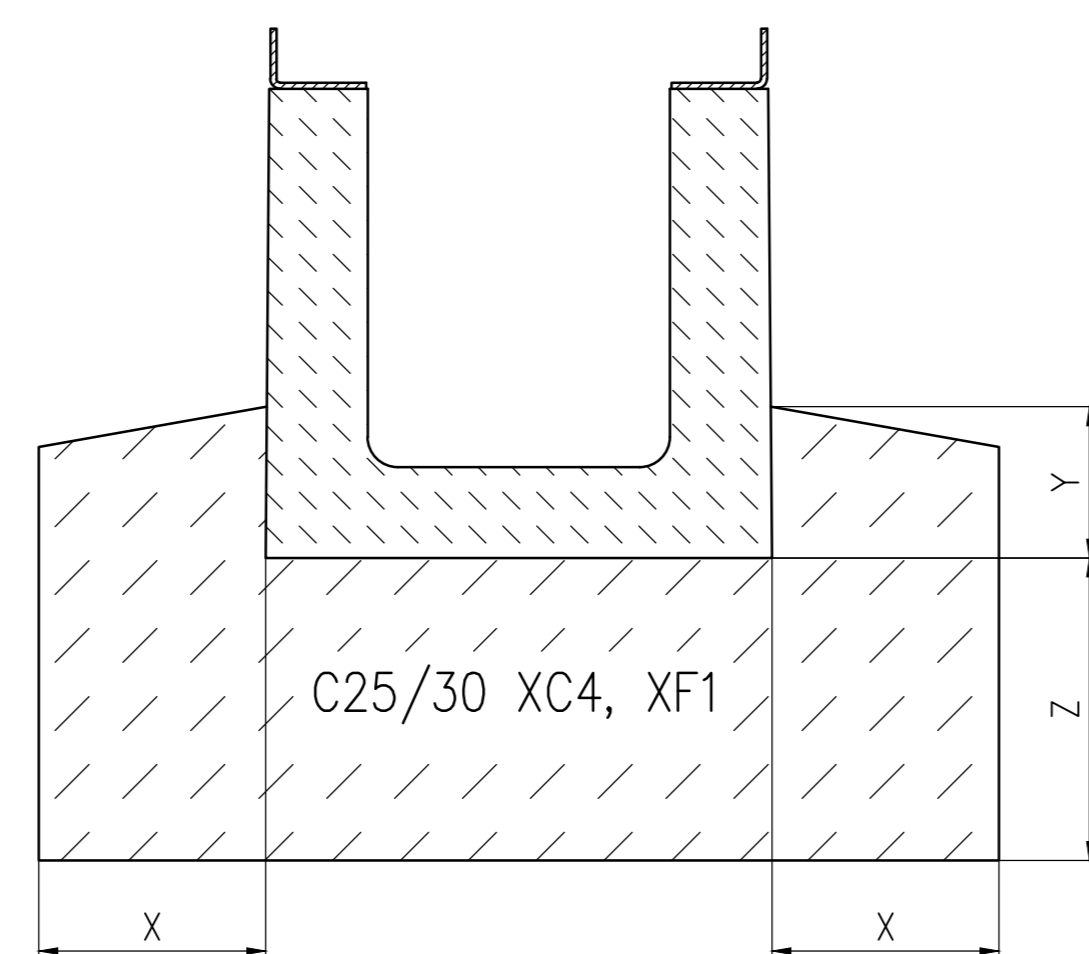

Load-class	X [mm]	Y [mm]	Z [mm]
A 15 – E 600	≥150	≥100	≥200

BIRCO SIR NW 200, Typ M

(expanded installation instructions for heavy-duty areas subjected to frequent use (class D 400 / E 600 / F 900) [*]
e.g. logistics centers, Transport hubs, maneuvering areas and aircraft pavements)

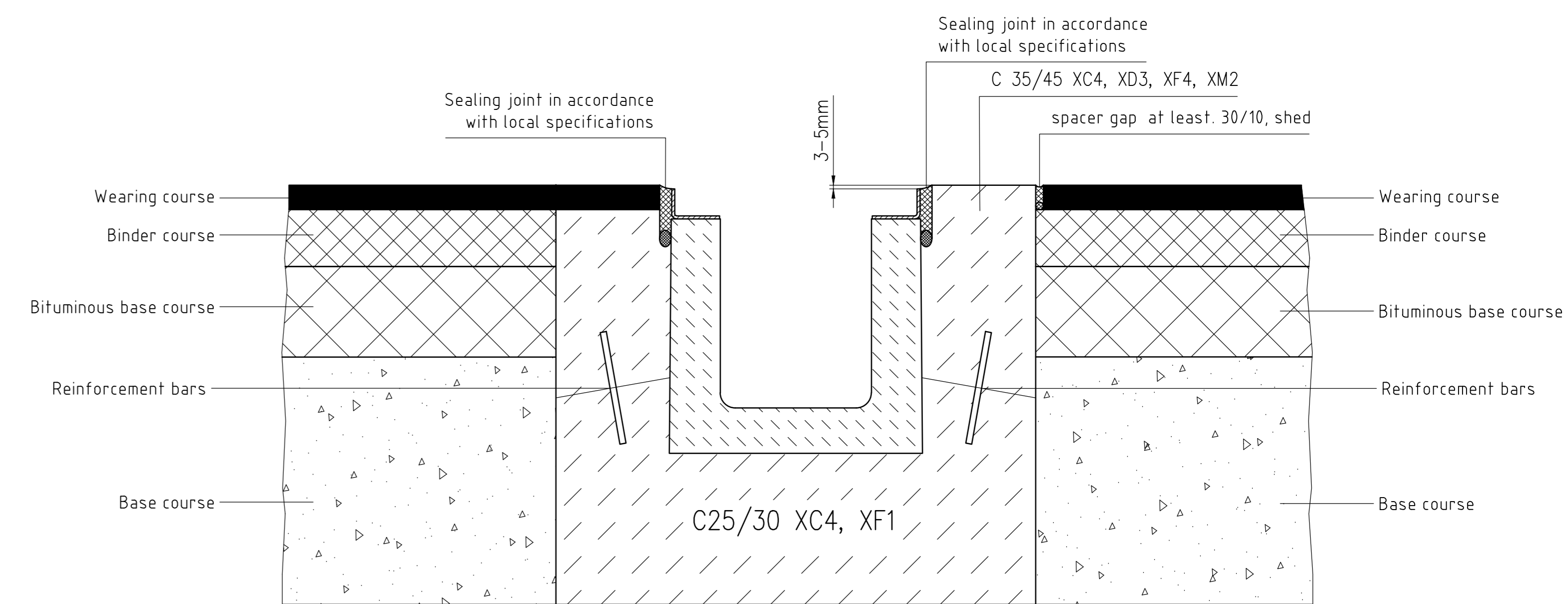

Constructed in accordance with local specifications using non-setting frost-free sub-bases (E.g. RST0)

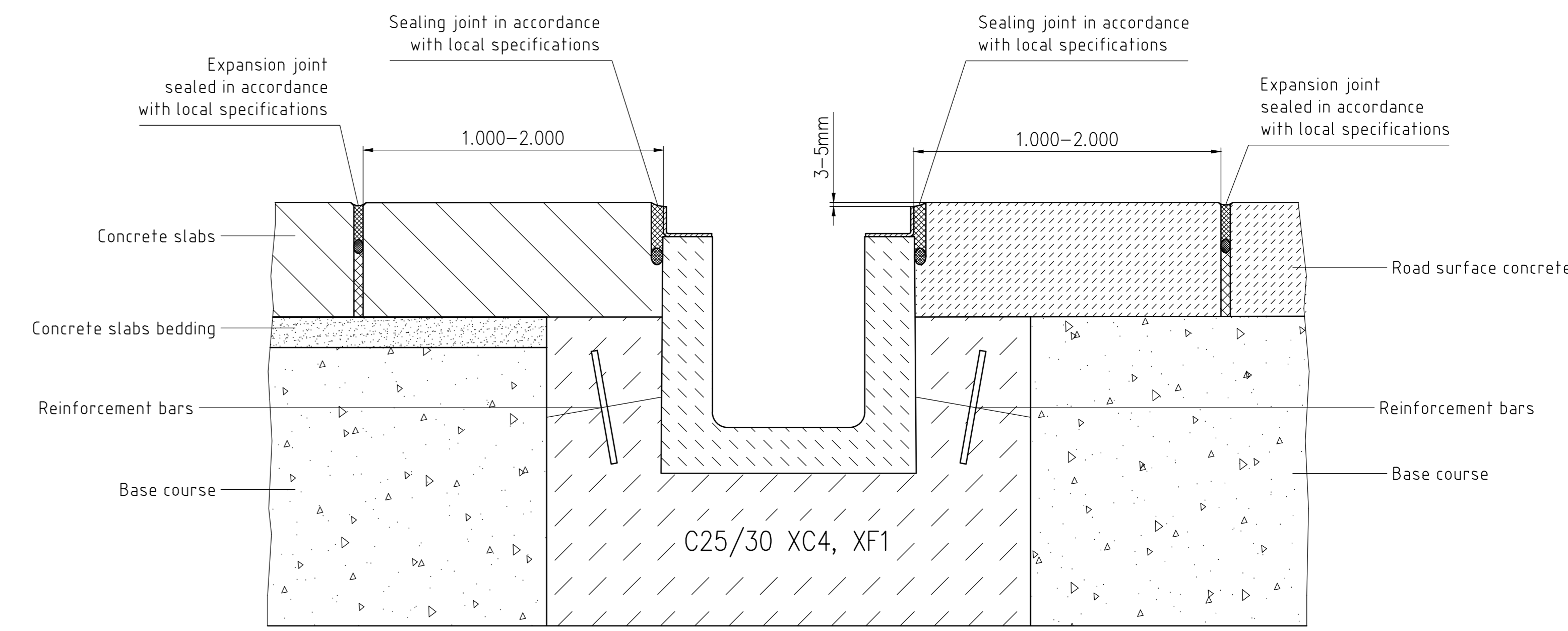

Constructed in accordance with local specifications using non-setting frost-free sub-bases (E.g. RST0)

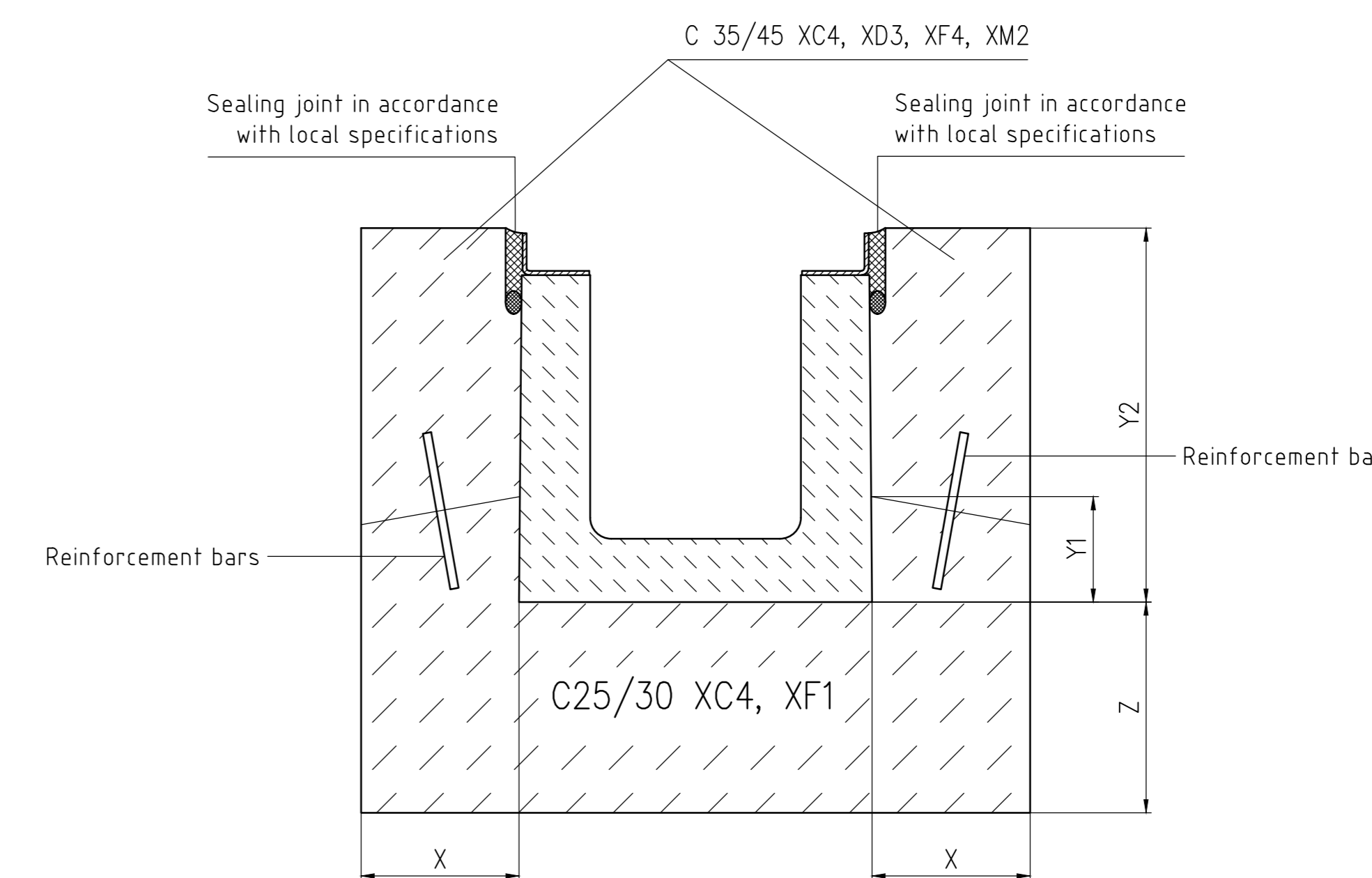

Load-class	X [mm]	Y1 [mm]	Y2 [mm]	Z [mm]
D 400 – E 600	≥150	≥100	height channel + 5mm	≥200

[*] Exception D 400: Not for installation across the roadway in highways and expressways

Pos.	Änderung	Datum	Name	gepr.
1	6681	15.05.20	siehe Änderungsmitteilung	mrr

Vertraulichkeit dieser Unterlage ist zu wahren. Schutzvermerk DIN 34 beachten.

BIRCO		BIRCO GmbH Herrenpöfel 142 76532 Baden-Baden	
Datum	Name	Benennung: Installation instructions	
22.06.2018	me	BIRCO canal NW 200 Typ M	
ges.		Load class A 15 – E 600	
Maßstab	Zeichn. Nr.	CAD	
1:5	2_VACAD\ENBAU\canal\NW200\20989_EN	A. B.	
Plot-Datum:			